

Dimension: (Unit: mm)

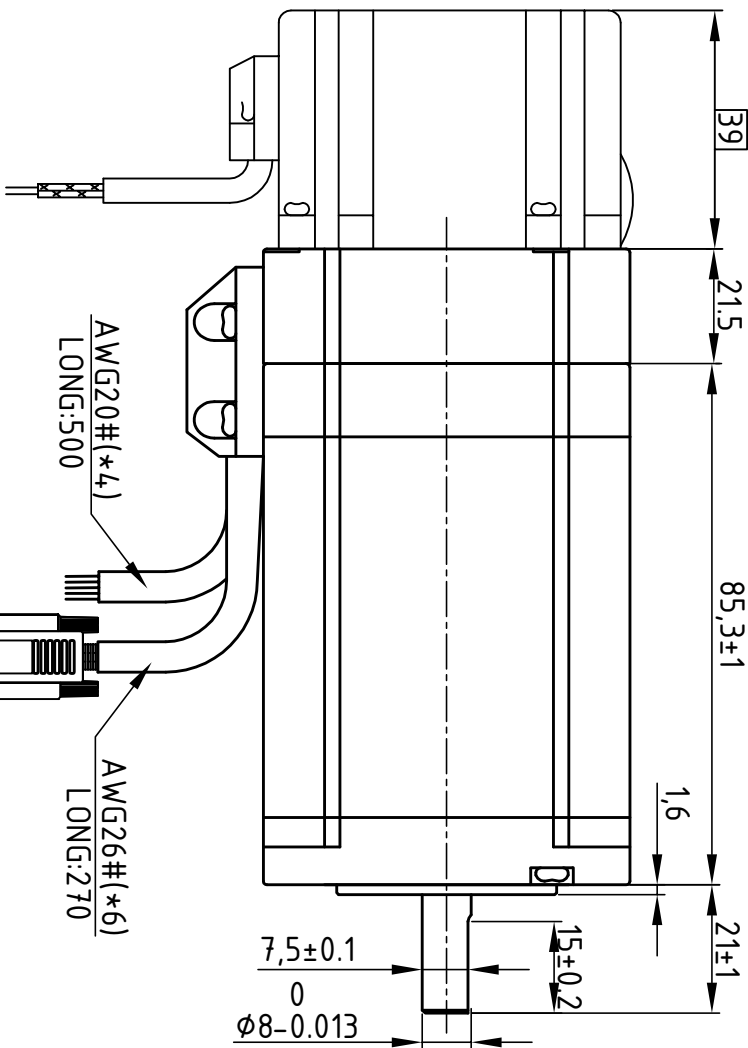

版本 Rev	日期 Date	变更文件号 ECU NO.	变更内容 Revisions	设计 By
V1.0	18.10.19		李林	王林林

Motor Connections:

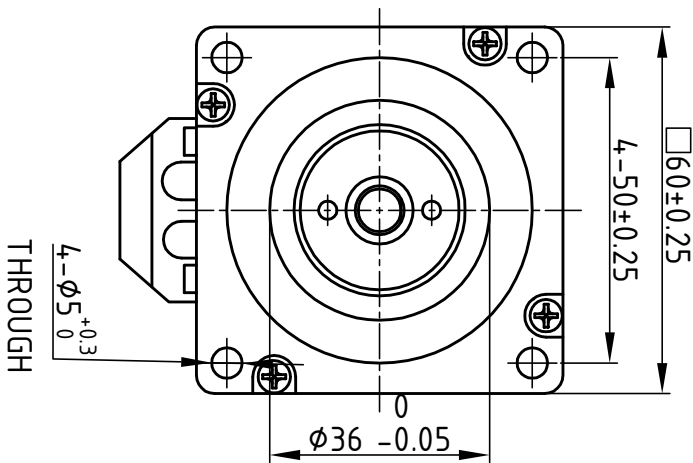
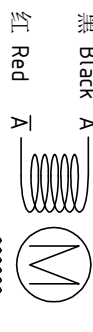

Encoder Signals

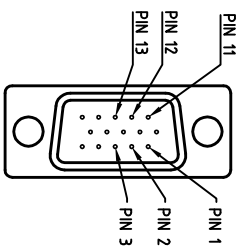

Common Rating

Step angle	1.8°
Position accuracy	1.8±0.09°
Dielectric strength	500VAC 1min
Insulation resistance	100MΩhm(500VDC)
Insulation class	B
Temp rise(Max)	80K
Radial play	Max:0.02mm(load 4.50g)
Axial play	Max:0.08mm(load 900g)

Brake Specification:

Voltage	24Vdc
Friction torque	2N·M

Motor Specification:

Current/phase	5 A
Voltage	2.3 V
DC Resistance/phase ±10%	0.46 Ω
Inductance/phase ±20%	2.0mH
Holding torque	3.0N·M
Inertia	0.69 kg·cm ²
Weight	1.8 kg
Encoder Resolution	1000 cpr

PIN	颜色	定义
1	黑	A+
2	红	VCC
3	白	GND
11	黄	B+
12	绿	B-
13	蓝	A-

Brake Connections

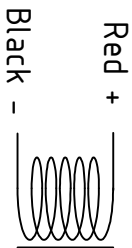

设计 Designed	王洪松	日期 Date	2018.10.19	材料 Material	
审核 Checked	黄捷建	2018.10.19		第一角画法 First Angle projection	
批准 Approved	黄捷建	2018.10.19		重量 Weight	
图号 Part No.				比例 Scale	
				图例 Mark	
深圳市雷赛智能控制股份有限公司 SHENZHEN LEADSHINE TECHNOLOGY CO., LTD.			图例 Title		
60CME30X-BZ			带抱闸混合伺服电机		
图号 DWG. NO.			LS-CME60-03-0111-06		