

Dimension: (Unit: mm)

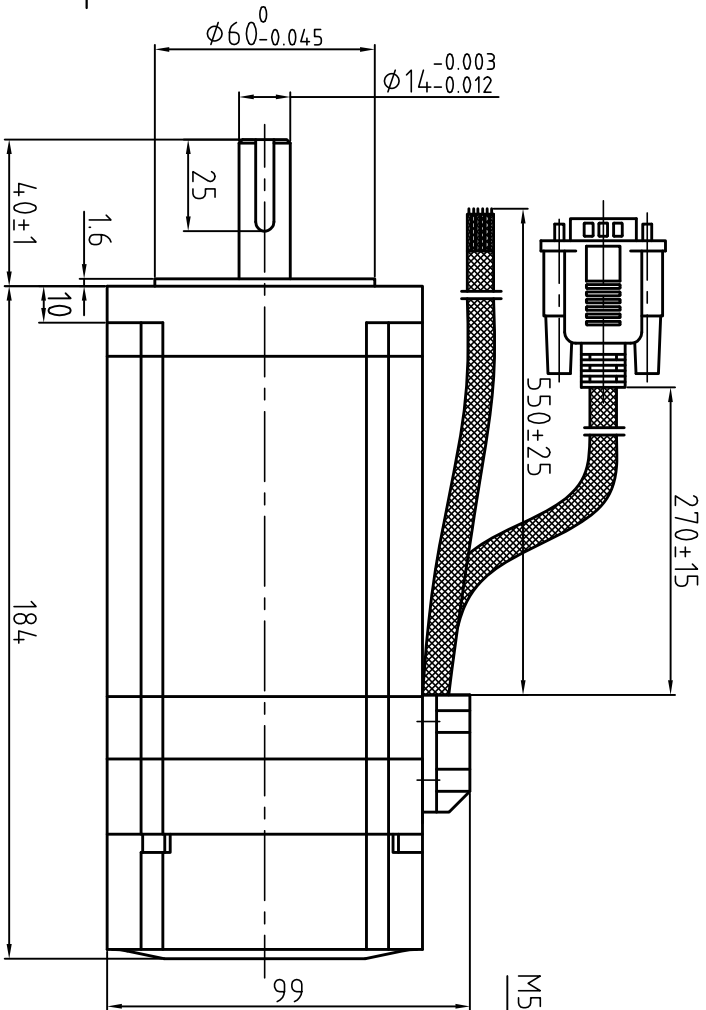

Common Rating

Step angle	18°
Position accuracy	18±0.09°
Dielectric strength	1500VAC 1min
Insulation resistance	100MΩhm(500VDC)
Insulation class	B
Temp rise(Max)	80K
Radial play	Max:0.02mm(Load 450g)
Axial play	Max:0.08mm(Load 900g)

Brake Specification

Voltage	24Vdc
Friction torque	4N·M

Specification

Current/phase	6 A
Voltage	5 V
DC Resistance/phase ±10%	0.83 Ω
Inductance/phase ±20%	7.8 mH
Holding torque	12 N·M
Inertia	3 kg·cm ²
Weight	5.4 kg
Encoder Resolution	1000 cpr

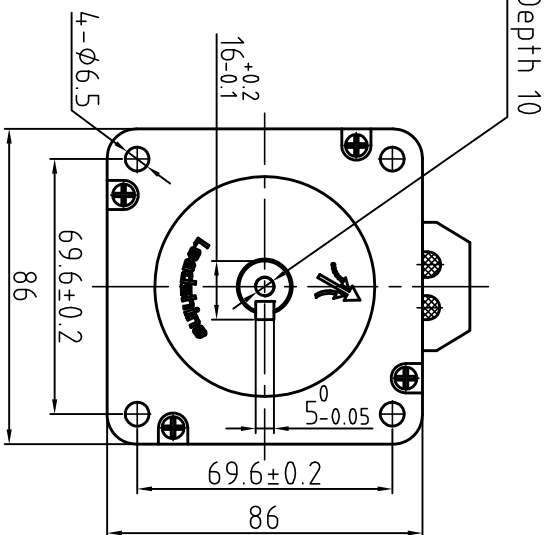

Motor Connctions

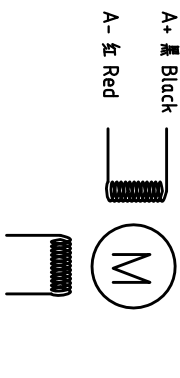

Brake Connctions

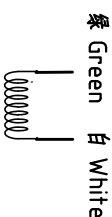

Encoder Signals

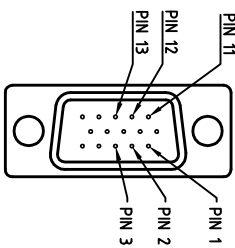

PIN	1	2	3	11	12	13
颜色	黑	红	白	黄	绿	蓝
定义	A+	VCC	GND	B+	B-	A-

设计	王洪松	日期	17.11.8	材料	深圳市雷赛智能控制股份有限公司 SHENZHEN LEADSHINE TECHNOLOGY CO., LTD.	
审核	秦军	17.11.8	第一角画法 First Angle projection	比例	86CME120-BZ	
批准	田天胜	17.11.8	重量 Weight	比例尺 Scale	86CME120-BZ	
图号 Part No.			共 1 套 第 1 套 Sheet 1 of 1	图号 DWG. NO.	LS-CME86-M05-0110-04	

版本 Rev:	日期 Date	变更文件号 ECR NO.	变更内容 Revisions	设计 By
V1.0	17.11.8		零缺陷	王洪松