

Dimension: (Unit: mm)

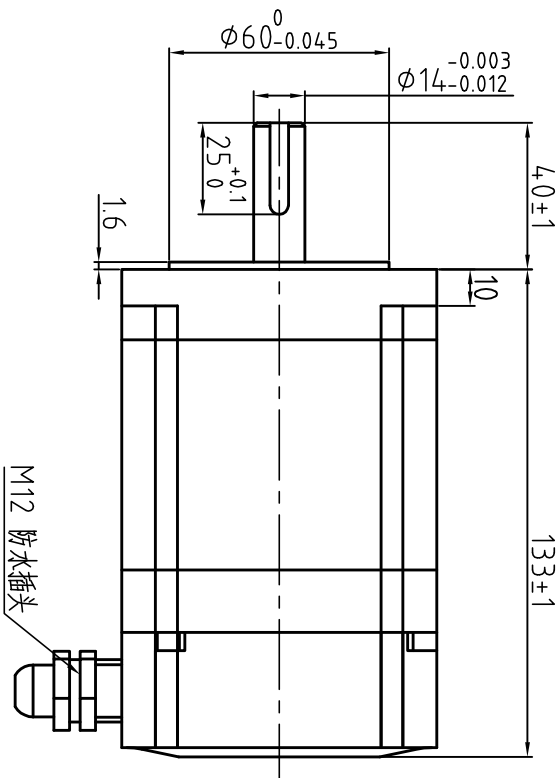

Common Rating

Step angle	1.8°
Position accuracy	1.8±0.09°
Dielectric strength	1000VAC 1min
Insulation resistance	100MΩhm(500VDC)
Insulation class	B
Temp rise(Max)	80K
Radial play	Max.0.02mm(load 4.50g)
Axial play	Max.0.08mm(load 900g)

Specification

Current/phase	6.0 A
Voltage	3.8 V
DC Resistance/phase	±10% 0.63 Ω
Inductance/phase	±20% 4 mH
Holding torque	8 N·M
Inertia	2.5 kg·cm ²
Weight	3.5 kg
Encoder Resolution	1000 cpr

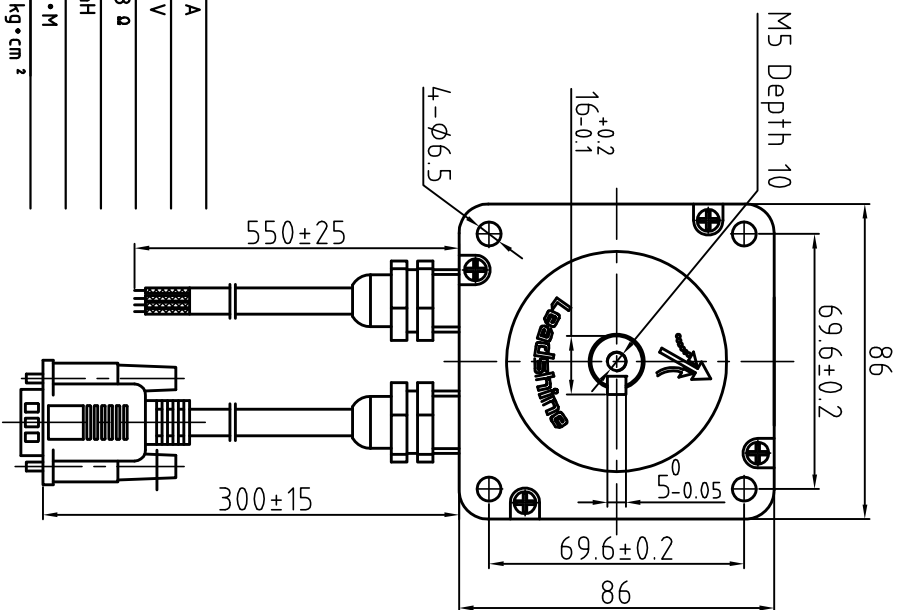

Motor Connections

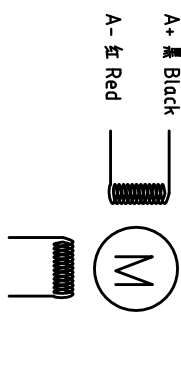

Encoder Signals

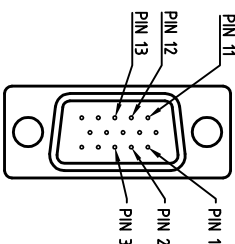

PIN	1	2	3	11	12	13
颜色	黑	红	白	黄	紫	蓝
定义	A+	VCC	GND	B+	B-	A-

技术要求:

1. 前出轴增加油封;
2. 电机定子表面做喷塑处理;
3. 前后端盖与定子间增加密封垫。

设计 Designed	王洪松	日期 Date	2017.11.10	材料 Material		
审核 Checked	秦罕	2017.11.10		第一角画法 First Angle projection		
批准 Approved	田天胜	2017.11.10		重量/比例 Weight/Scale	图例/标志 Symbol/Mark	标题 Title
图号 Part No.				共 1 套 第 1 套 Sheet 1 of 1	图号 DWG. NO.	LS-CME86-03-5210-04
				深圳市雷赛智能控制股份有限公司 SHENZHEN LEADSHINE TECHNOLOGY CO., LTD.		
				混合伺服电机 86CME80-FS		

版本 Rev	日期 Date	变更文件号 ECU NO.	变更内容 Revisions	设计 By
V1.0	2017.11.10		附件增加 IP67	王洪松